

Coal to Ammonia

Presented at the
Iowa Energy Center Meeting
Ammonia-The Key to a Hydrogen Economy

By
Mark Ibsen
Rentech Development Corporation

October 13, 2005

Presentation

- Rentech Introduction
- Producing Ammonia from Coal/Petroleum Coke Gasification
- What is Fischer-Tropsch?
- East Dubuque, Illinois
- Environmental Benefits
- Food Security and Energy Security-Fuel for First Responders, and the US Military

Rentech – A Brief History

- A 23 year old Denver, Colorado Energy Technology Company
 - Traded as “RTK” on the American Stock Exchange
- Engaged in the Fischer-Tropsch Development
 - Coal-to-Liquids (FT/CTL) business
 - NG-to Liquidss (FT/GTL) business
- Licenses its patented and proprietary technology
 - 20 U.S. and 1 foreign process and materials patents
- Rentech Development Corporation
 - Subsidiary of Rentech Inc.
 - Responsible for ownership and development
 - Gas-to-Liquid and Coal-to-Liquid Projects

Coal to Ammonia a New Concept?

- Not really but for the United States, yes
- Today, in the US there are two projects operating
 - North Dakota Gasification
 - Coffeyville Resources
- World Wide a number of facilities
 - China (2500 small local facilities)
 - Portugal (uses refinery bottoms)
 - Germany, Czech, India, Brazil all have ammonia plants from coal
- Key driver, high NG costs

North Dakota Coal Gasification



Coffeyville Nitrogen Plant



Syngas Derived Products

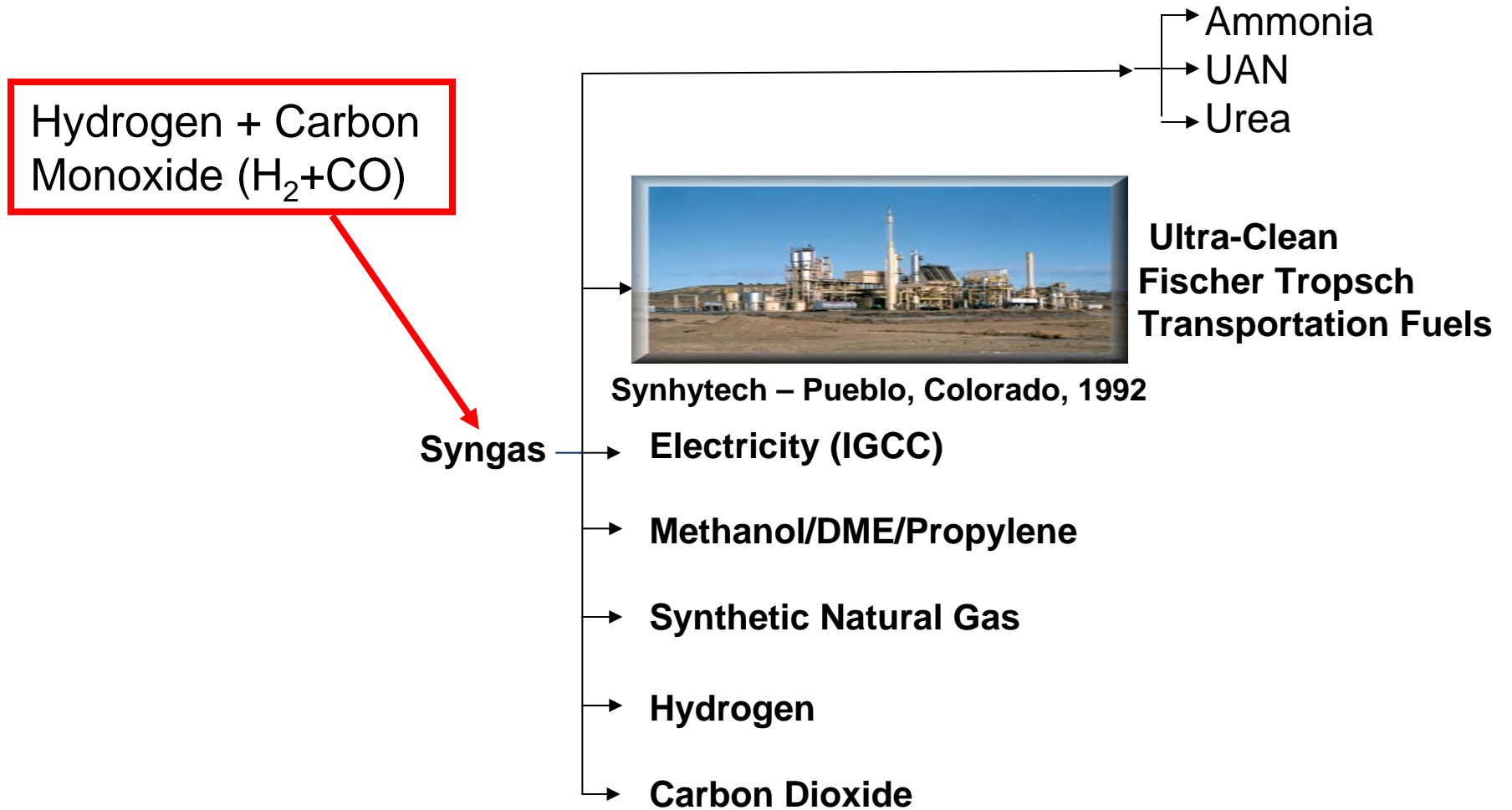

Gasification Ideal for Syngas Derived Products

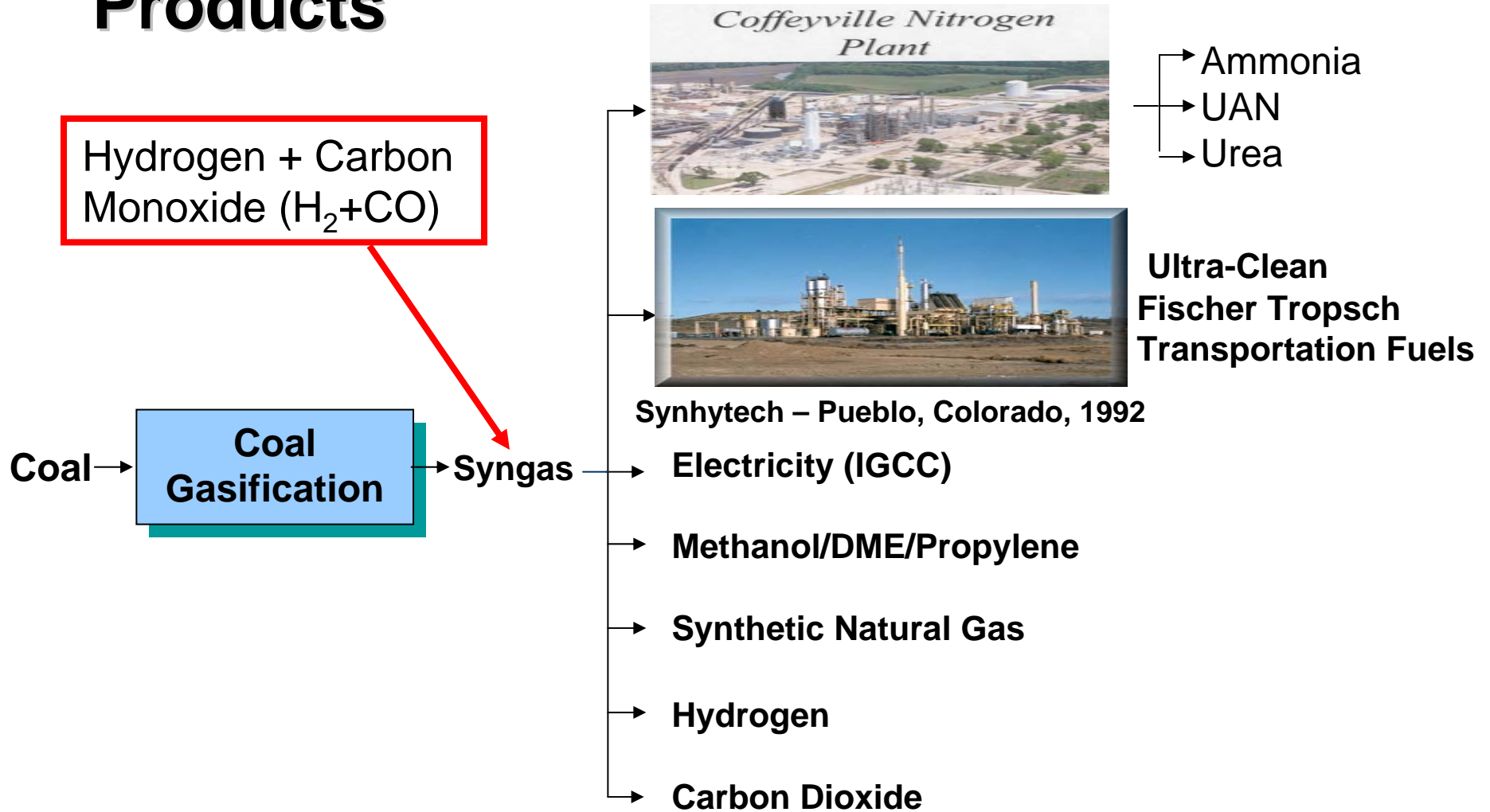



Illinois
Coal to Corn
Project

First Mover Opportunity: Producing Fertilizer, Ultra-Clean Fuels & Electricity From Coal

Deploy gasification to save and create jobs while increasing energy and food security through the production of ammonia and FT liquids using Illinois coal as the plant feedstock.

Fischer-Tropsch (FT) Synthesis

- **Invented by German chemists** Franz Fischer and Hans Tropsch in 1923. Used by Germany during WWII to produce 600,000 bbl/year of fuels from coal and coke
- **Commercially proven worldwide**
197,000 BPD Current Production
 - Since 1950s ~ currently 160,000 bbl/day from coal by Sasol
 - Since 1993 ~ 23,000/bbl/day from natural gas by Petro SA using Sasol technology
 - Since 1995 ~ 15,000/bbl/day from natural gas by Shell in Malaysia

FT is Commercially Proven Worldwide

SASOL (S. Africa)

- 45 years commercial
 - 160,000 b/d+
 - Feedstock Coal

SASOL'S SOUTH AFRICAN FACILITY



MossGas (S. Africa)

- 11 years commercial
 - 22,500 b/d+
 - Feedstock Natural Gas



Shell (Malaysia)

- 9 years commercial
 - 15,000 b/d+
 - Feedstock Natural Gas



Why Rentech?

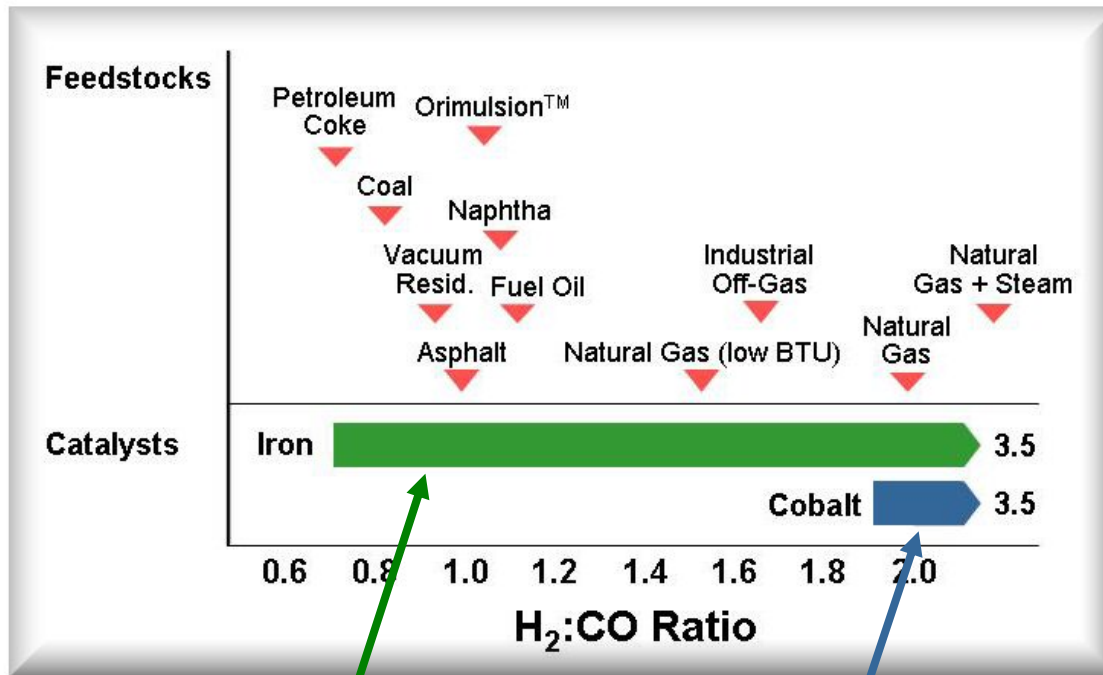

Catalyst Flexibility

CTL
RENTECH
SASOL

GTL
CONOCO
EXXON
SHELL
CHEVRON/SASOL

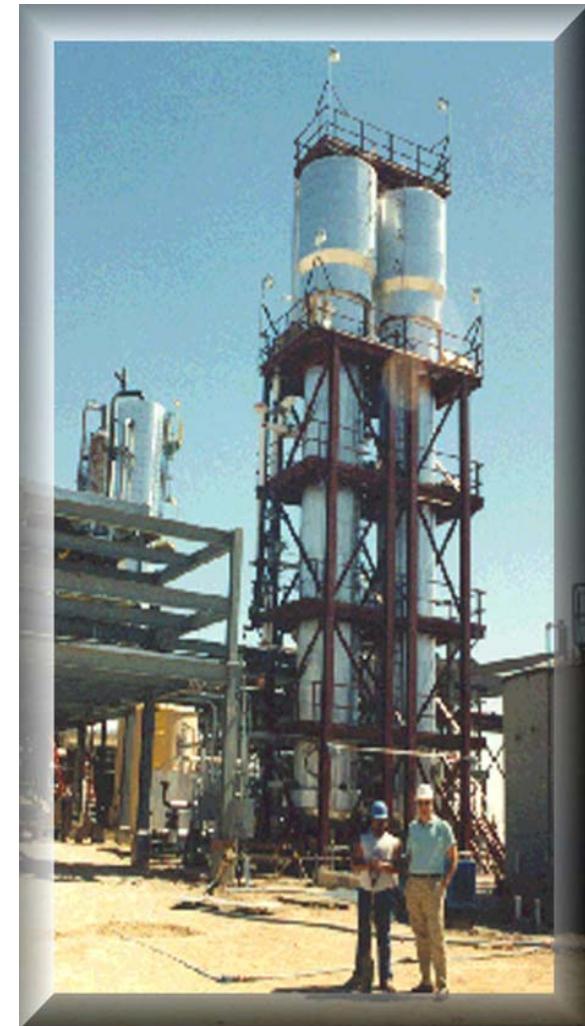

World's Largest FT Slurry Reactor – Synhytech, 1992¹⁵



Rentech CTL with Fertilizer

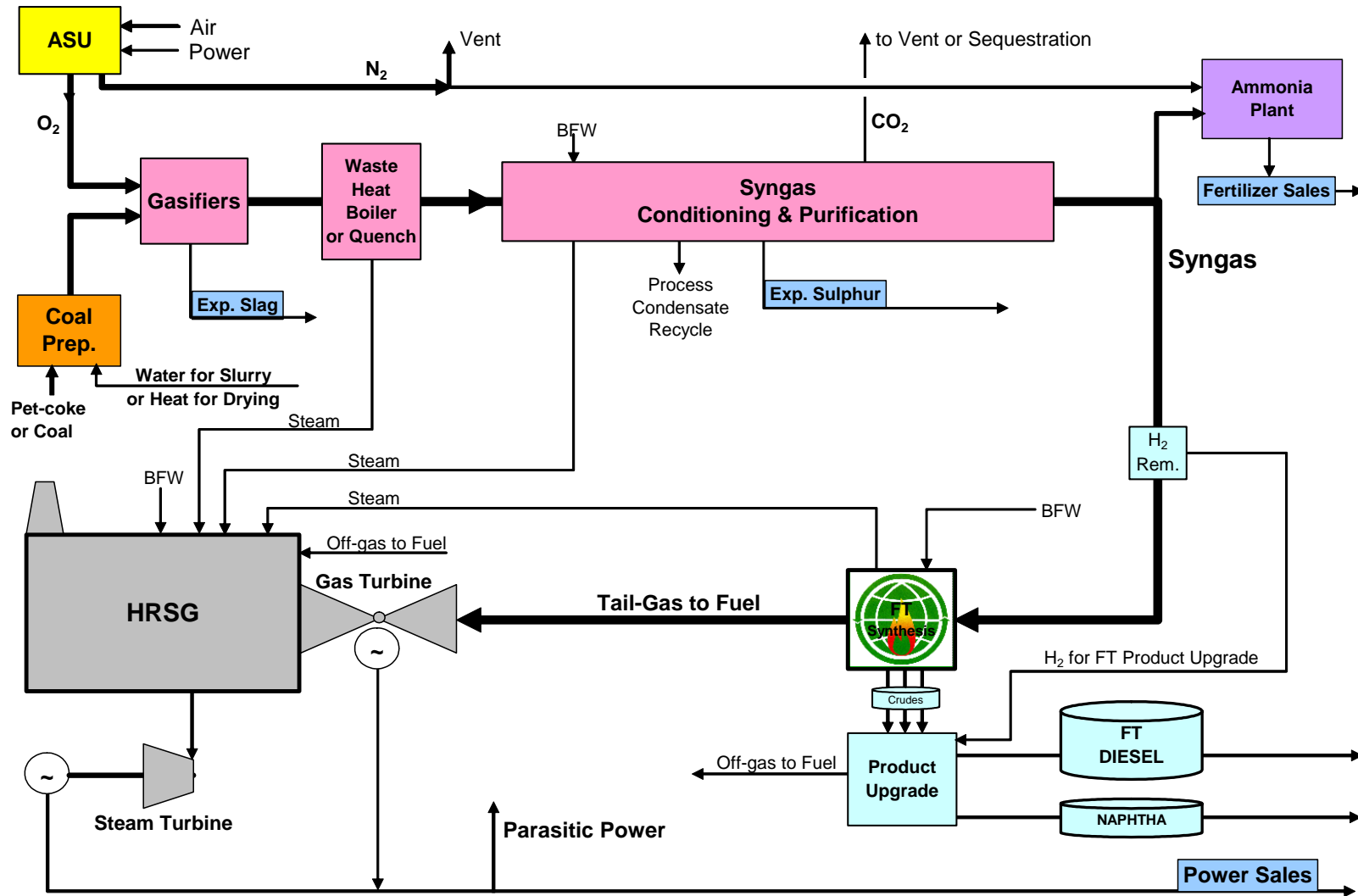



*East Dubuque
Plant*

U.S. Ammonia Production vs. Natural Gas & Coal Price

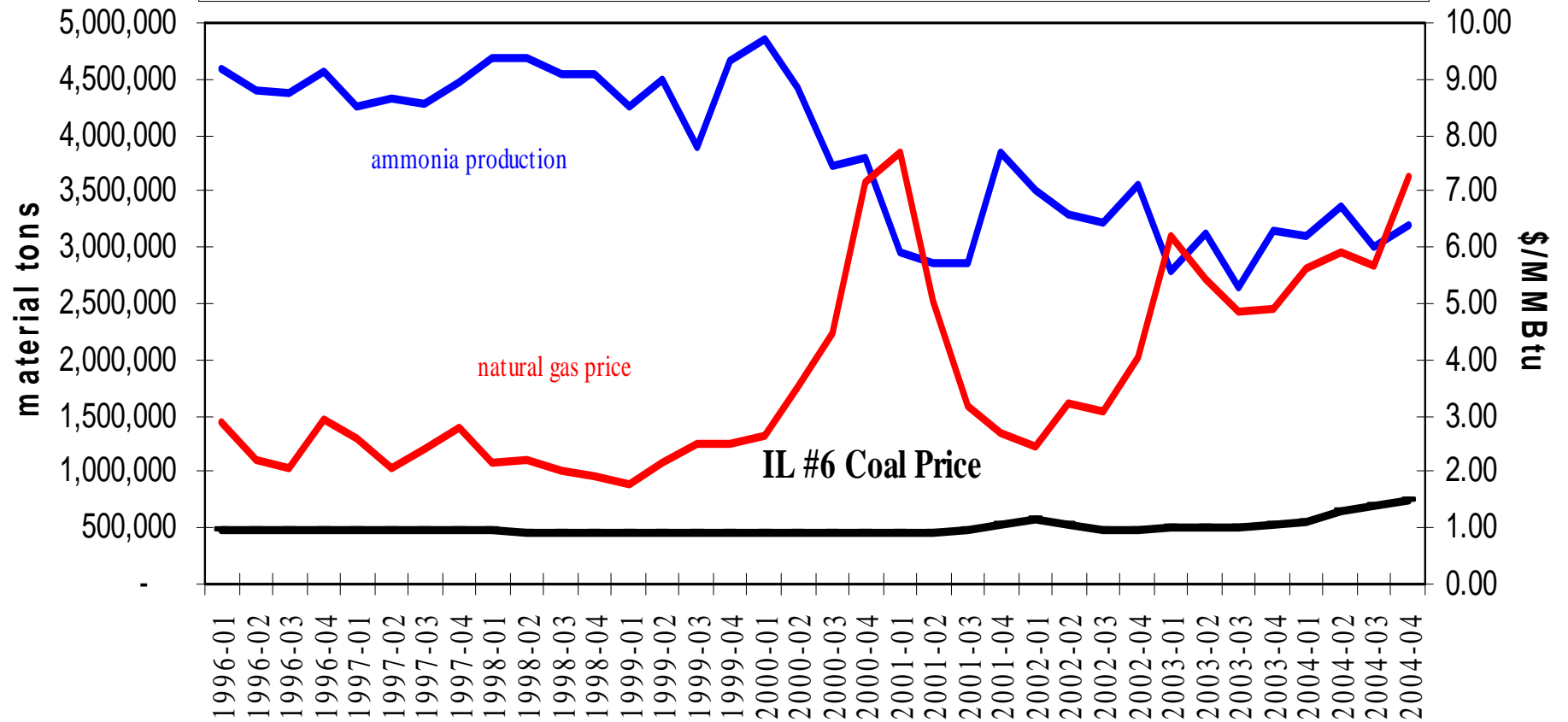

Source: Ammonia production, U.S. Department of Commerce; natural gas price - average spot-delivered-to-pipeline price, Natural Gas Week.

The RC Plant Post Conversion to Coal Feedstock Integrated Manufacturing Process

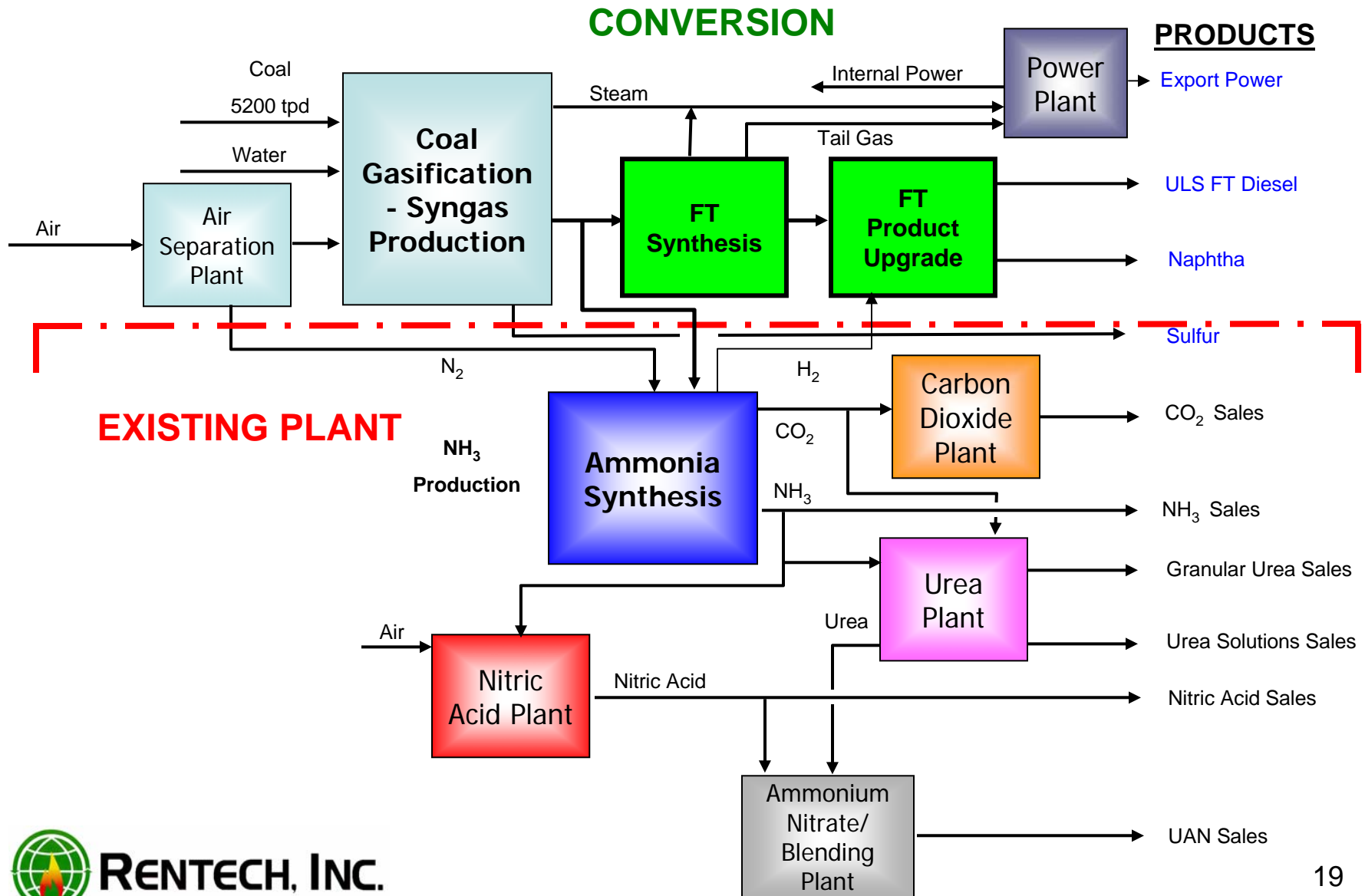

Coal Gasification Yielding Rentech FT Fuels & Power & Ammonia (Simple Recycle FT Process, 1 Gasifier)

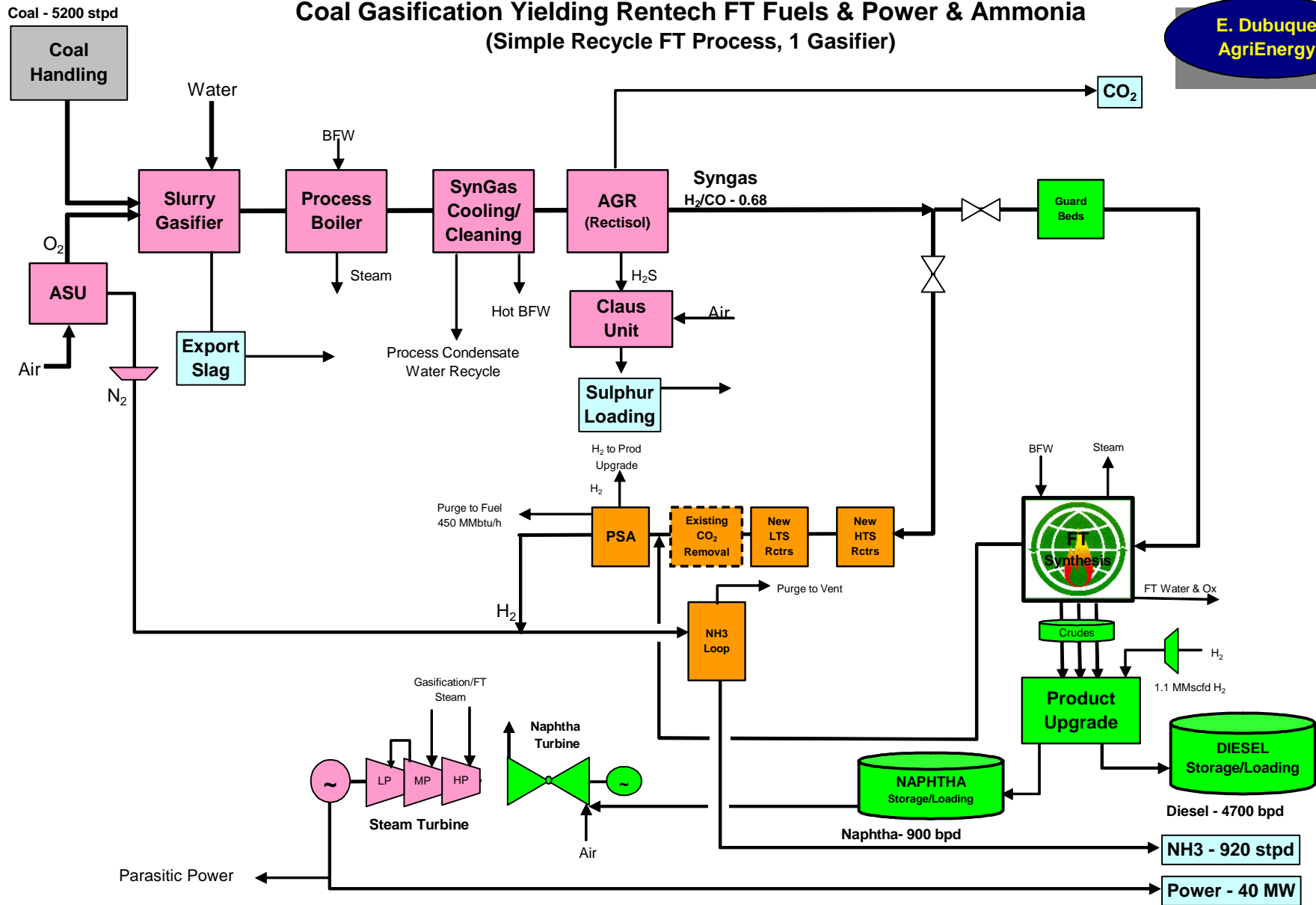

Color Legends:

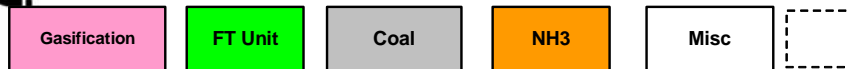

Indicates units that may or may not be needed.

East Dubuque Plant Polygeneration Model Estimated Inputs and Production

- Coal feedstock 5,200 TPD

Products (45% Increase in Tons Shipped)

- Ammonia production 920 TPD
- FT Fuels (80% diesel) 5,600 BPD
 - 248,000 gallons per day
- Electricity production 160 MW(e)
- Electricity export 40+ MW(e)

Benefits of Polygeneration from Coal

- Standard pulverized coal power plant: **35%**
- Combined cycle natural gas power plant: **45%**
- Coal gasification to produce fertilizer, ultra-clean fuels, & electricity: **50+%**

Coal Cleaner?

Plant Regulated Emissions

With a Production increase of 45% in Tons Shipped

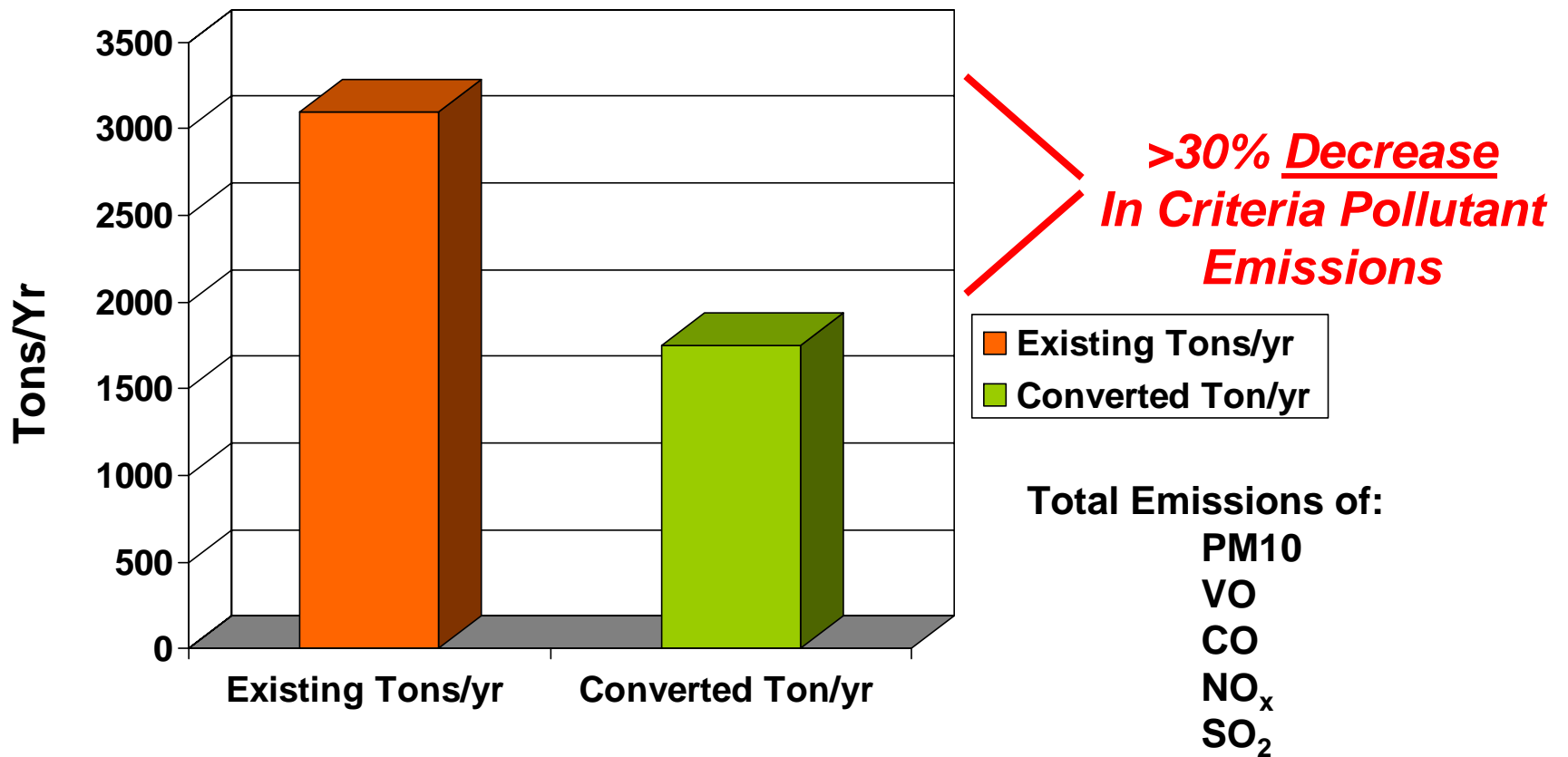

Ultra-Clean FT Diesel Fuel from Coal

- Biodegradable
- < 1ppm Sulfur
- High Cetane
- Stable long storage life

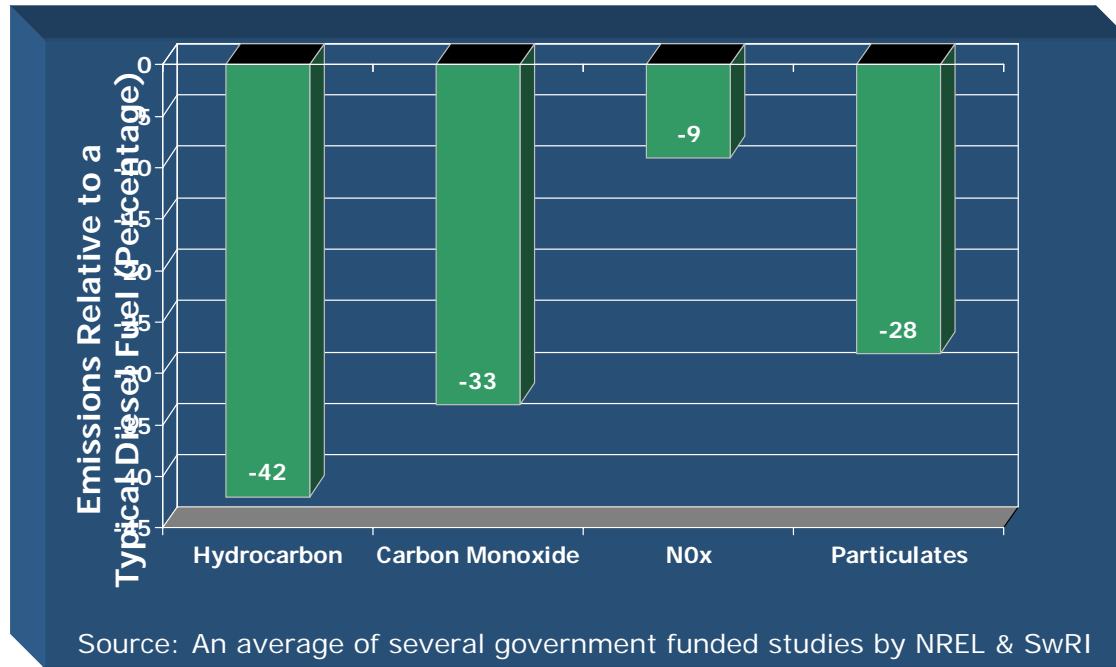

FT Diesel



Conventional Diesel

FTD from coal is an "alternative fuel" under 1992 Energy Policy Act (EPACT)

OSD Clean Fuel Initiative

Vision: DoD catalyze the commercial industry to produce clean fuels for the military from secure domestic resources using environmentally sensitive processes that create jobs and wealth in the United States

Dr. Theodore K. Barna
Assistant Deputy Under Secretary of Defense
Advanced Systems and Concepts
Pentagon 3D833
703-695-9873
Ted.Barna@OSD.mil

DoD Impact

- Secure and reliable sources of energy
 - Currently dependent on foreign oil
 - Becoming dependent on foreign **refined** fuels
- Supply chain vulnerability
 - Dependent on mega refineries- Gulf Coast
 - Natural disasters or Terrorist threats
- Need for cleaner fuels
 - DoD exempt from some EPA regulations
- Potential limits on deployments
 - Possible conflict with EU rules

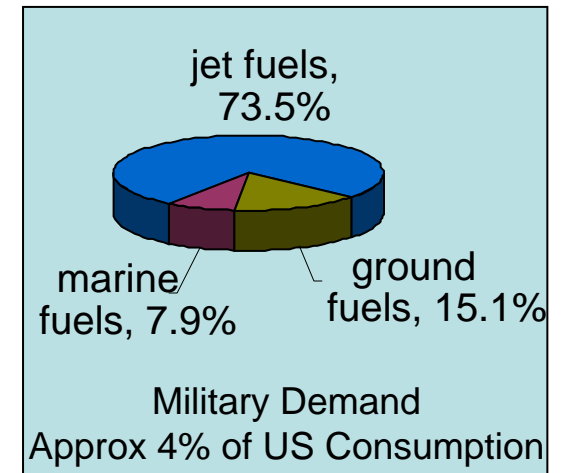

Ref: DESC Help Book

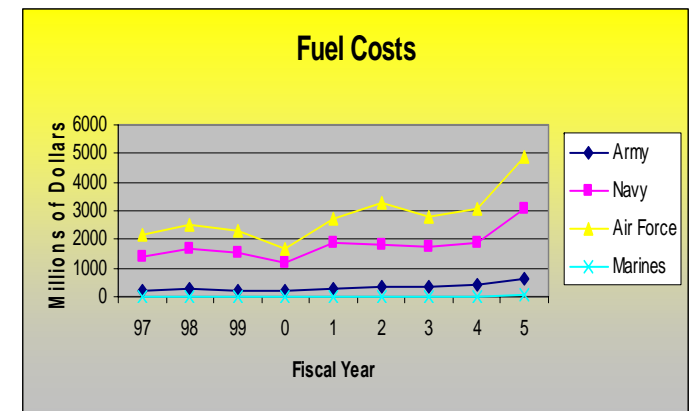

Total Energy Development (TED)

- Use all secure indigenous sources of energy
 - Coal, shale oil, petroleum coke, renewables
 - Dispersed production facilities
- Minimize government funding—focus on qualification and certification
- Make a better fuel from coal and petroleum coke (Fischer Tropsch fuels) and oil shale
 - Low (or no) sulfur, cleaner burning, bio-degradable, low (or no) aromatics, reduced particulate emissions
 - Blends near term, neat fuel future goal
 - Stable fuel for long term secure storage of refined fuel for emergency use
- Use Environmentally sensitive processes to produce fuel
 - Clean Coal Technologies such as the Fischer-Tropsch process, Mahogany Shale Research Project
 - CO₂ sequestration for enhanced oil recovery (EOR)

Reduced Exhaust Emissions with FT Fuel Relative to Low-Sulfur Diesel Fuel

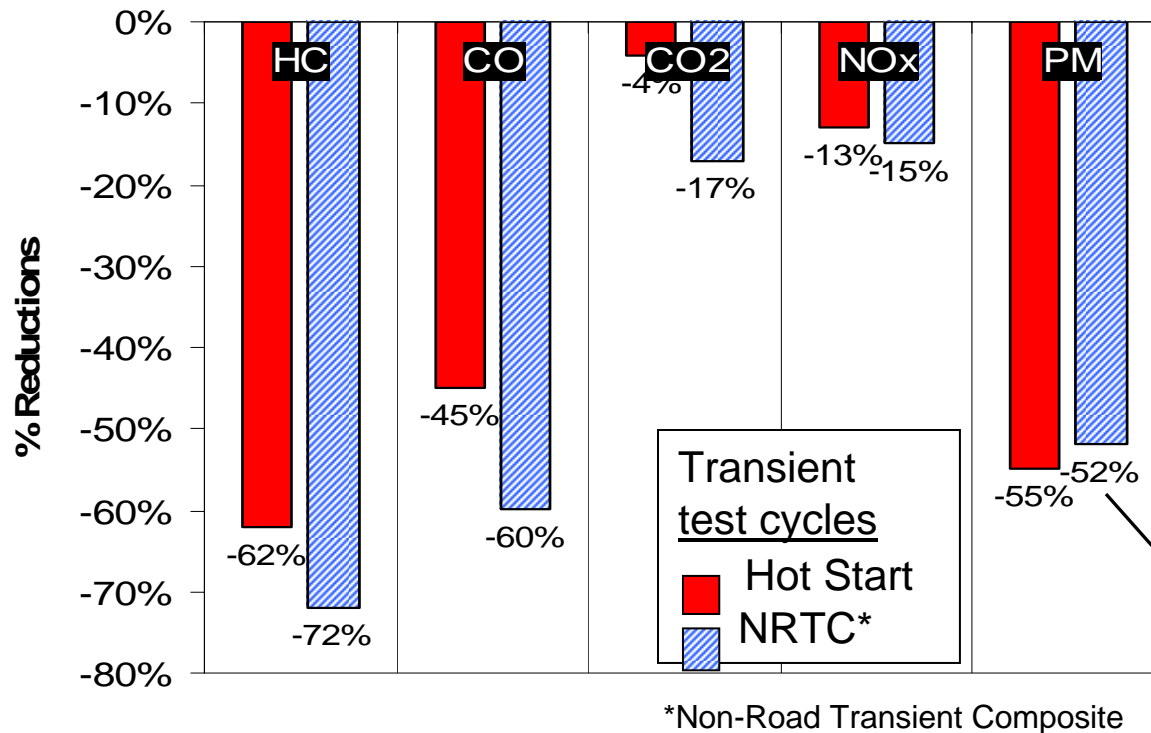

Over 50% reduction in particulate emissions in transient mode.

FT fuel burns more completely and emissions are significantly cleaner than EPA certified low-sulfur diesel fuel tested in 6.5L diesel engine.

Reduced Particulate Emissions with FT Fuel Relative to JP-8

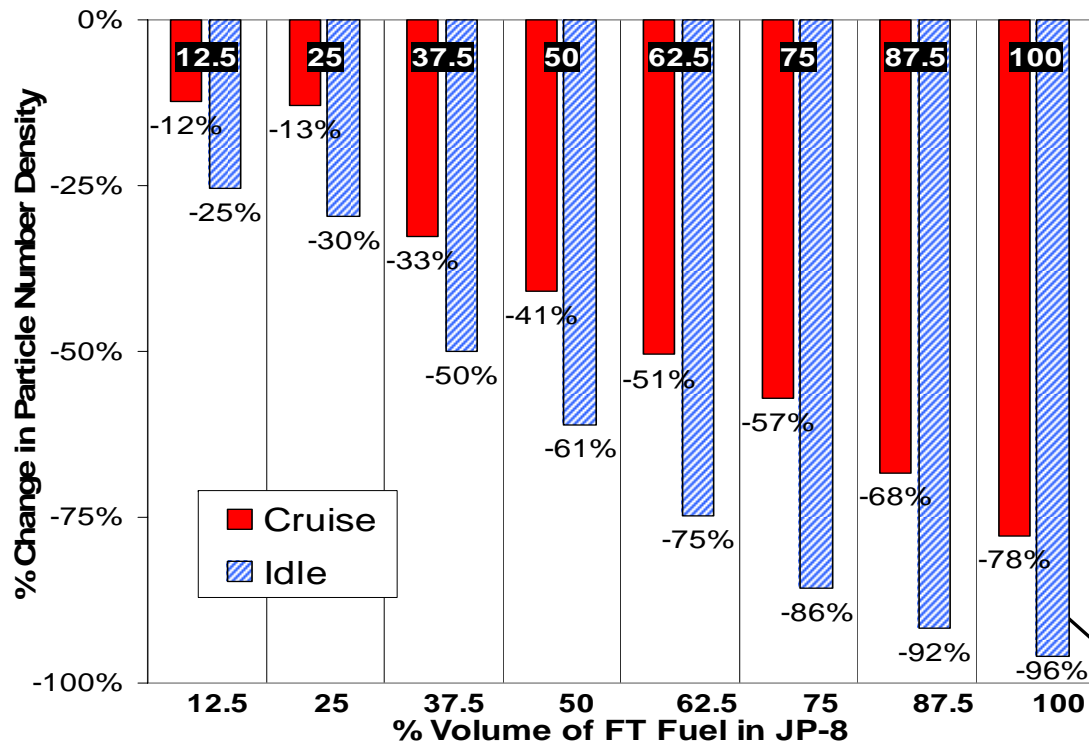

96% reduction* in particulate emissions at idle conditions.

Even moderate fractions of FT fuel blended in JP-8 significantly reduce exhaust emission particulates in T63 turbine engine testing.

* Note: Results are highly dependent on engine model/year and composition of baseline fuel.

Summary

- Coal to Ammonia is not a new concept
- The Poly-generation concept improves plant efficiency and diversifies product mix
- Conversion of existing facilities improves project schedule, reduces cost and utilizes existing plants
- The Ammonia and Fuels provide for Food and Fuels security for the United States
- Both Ammonia and FT liquids are a steps toward the Hydrogen Economy
- Polygeneration provides diversity and stability to ammonia plants during market swings.

Questions